

X6 E Band Active Multiplier



Product Overview

AT-AM6-7186-12 is a E band, active x6 frequency multiplier. The multiplier has an input frequency of 11.8 to 14.4 GHz with a typical output +12dBm from 71-86GHz.

The integrated input and output buffers deliver high output power at a low drive level. The multiplier also has a typical harmonic suppression of -20dBc. The input port is SMA female, and the output is a WR-12 waveguide with a standard UG-387 flange. It also can be used from 68-88GHz with some reduce of performance.

More information, please visit www.atmicrowave.com

Advantages

- ✓ Frequency: 71-86GHz
- ✓ Pout: +12dBm typical
- ✓ Input: 11.8-14.4GHz, +5dBm
- ✓ Single Supply: +5V

Application

- ✓ E band Communication
- ✓ FOD (Foreigner Objects Debris)
- ✓ Test Equipment
- ✓ ROF (RF Over Fiber)
- ✓ Radar System

Key Features

Parameter	Min	Typical	Max
Input Frequency	11.8GHz		14.4GHz
Input Power	+5	+6dBm	+10dBm
Output Frequency	71GHz		86GHz
Output Power	+10dBm	+12dBm	
Harmonica Suppression		-20dBc	
Drain Voltage		+5V	+8V
Current		150mA	
Spec Temp		25C	





AT-AM6-7186-12

Active Multiplier x6, 71-86GHz Pout=+12dBm

Mechanical Information

Item	Description
Input Port	SMA Female
Output Port	WR-12
Case Material	Copper
Finish	Gold Plated
Weight	120g
Size:	See outline

Absolute Maximum Ratings Table

Parameter	Value
Drain Supply	+9V
RF Input Power	+15dBm
Operating Temperature	0 to 50 C
Storage Temperature	-65 to +150C

Notes:

1. Datasheet may be changed according to update of MMIC, Raw materials , process, and so on.
2. This data is only for reference, not for guaranteed specifications.
3. Please contact AT Microwave team to make sure you have the most current data.



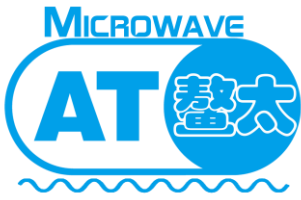

AT-AM6-7186-12

Active Multiplier x6, 71-86GHz Pout=+12dBm

Test Data:

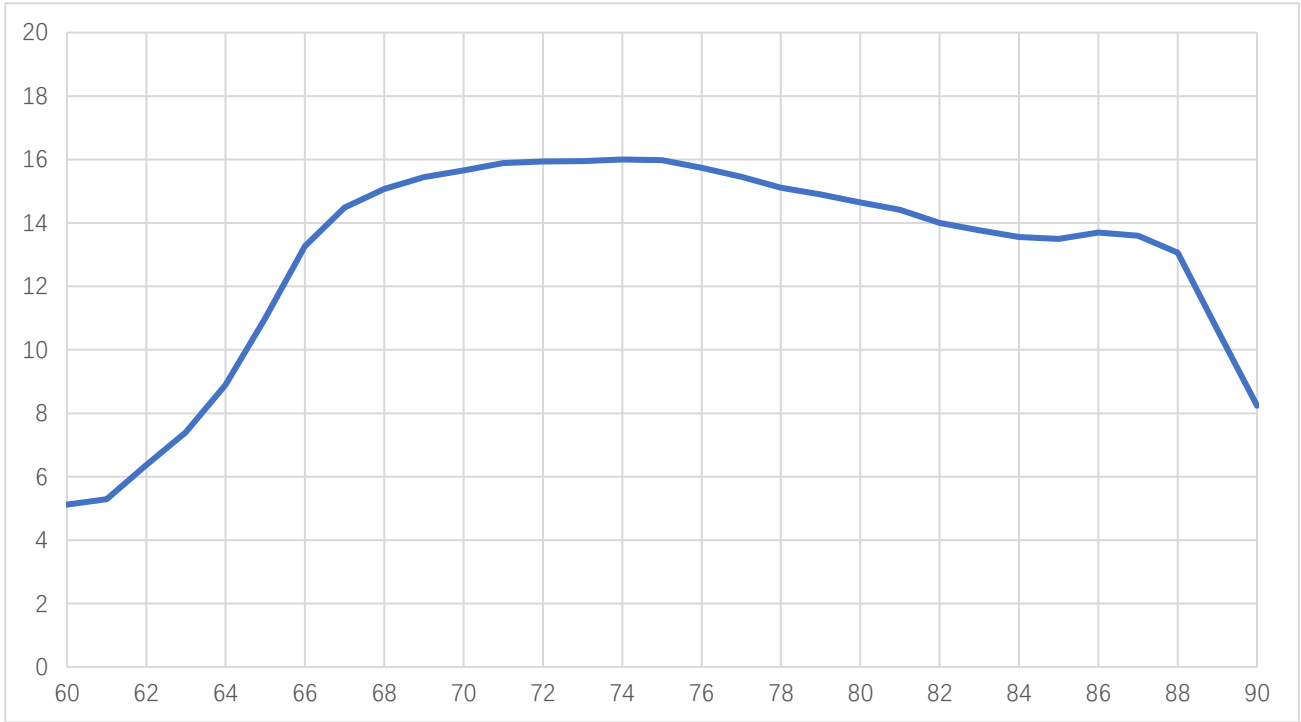

Pout Vs Frequency, Pin=+6dBm

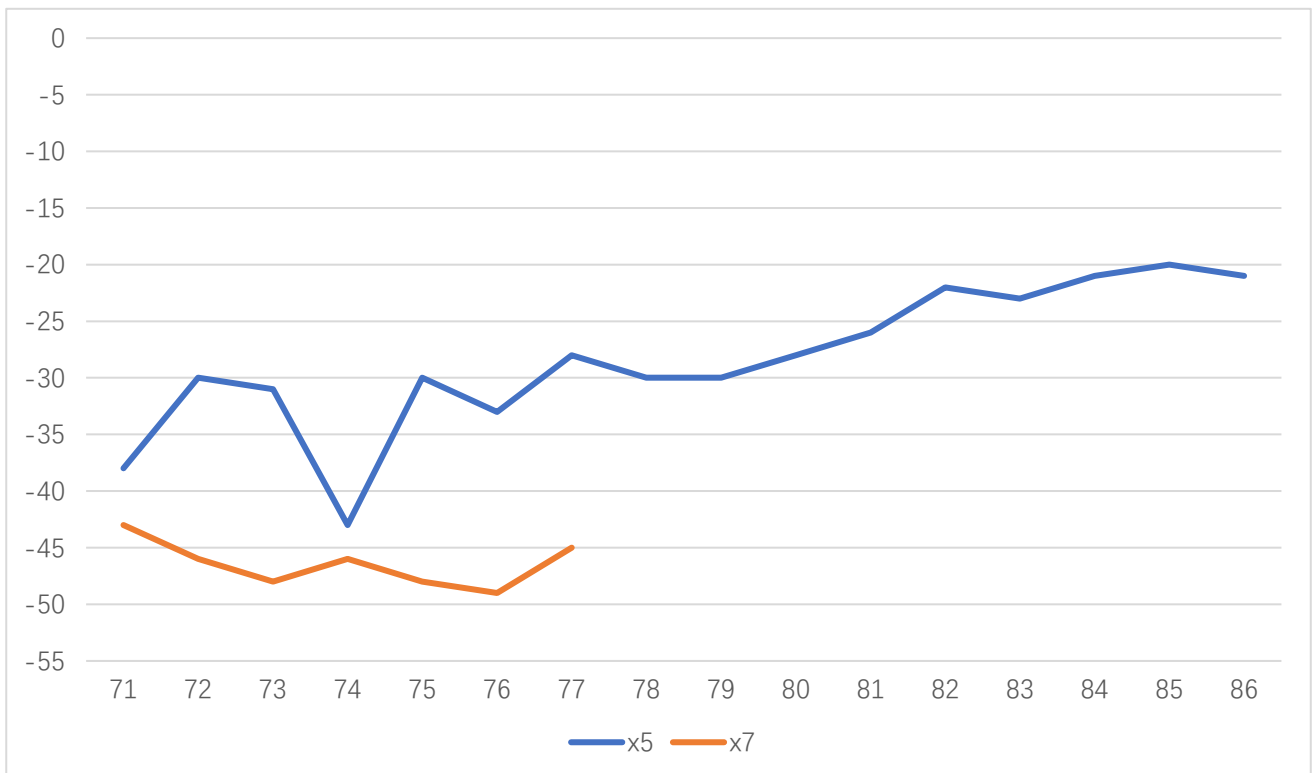

X5/X7 Harmonics Suppression vs X6 Pout



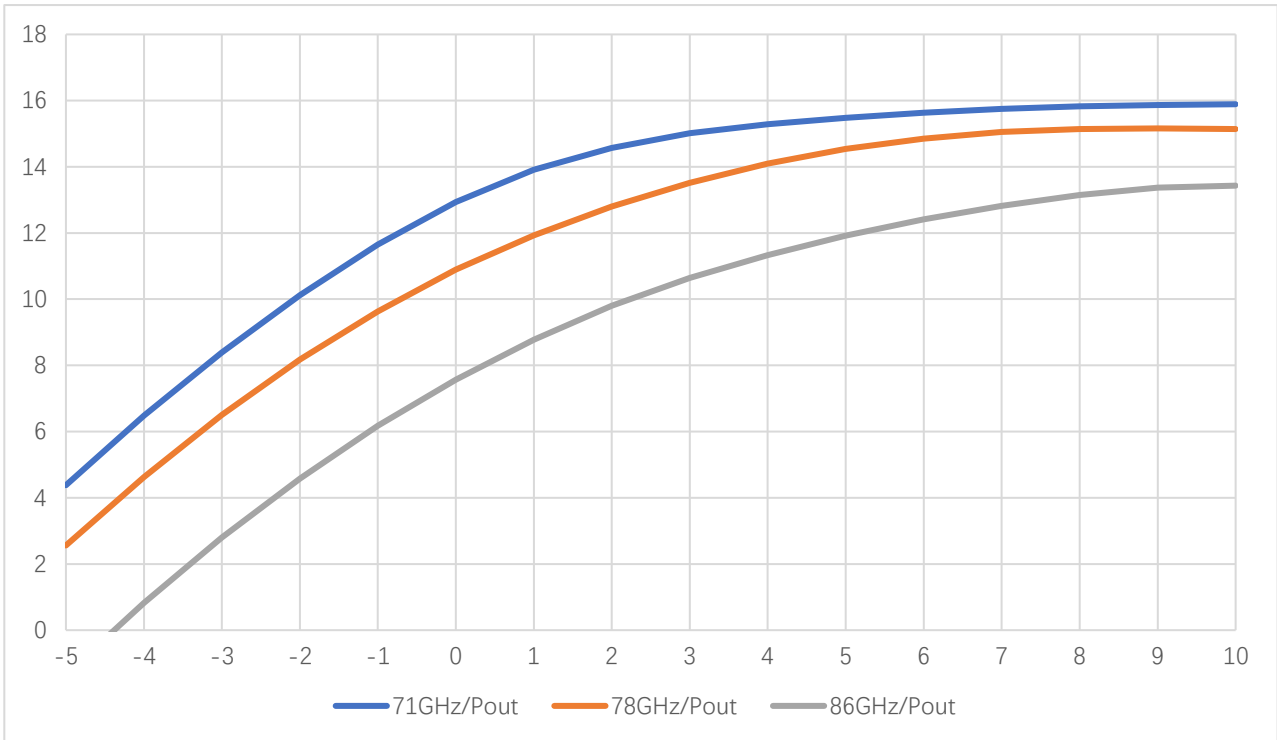

Pout vs Pin at 71/81/86GHz

E Band 60-90GHz

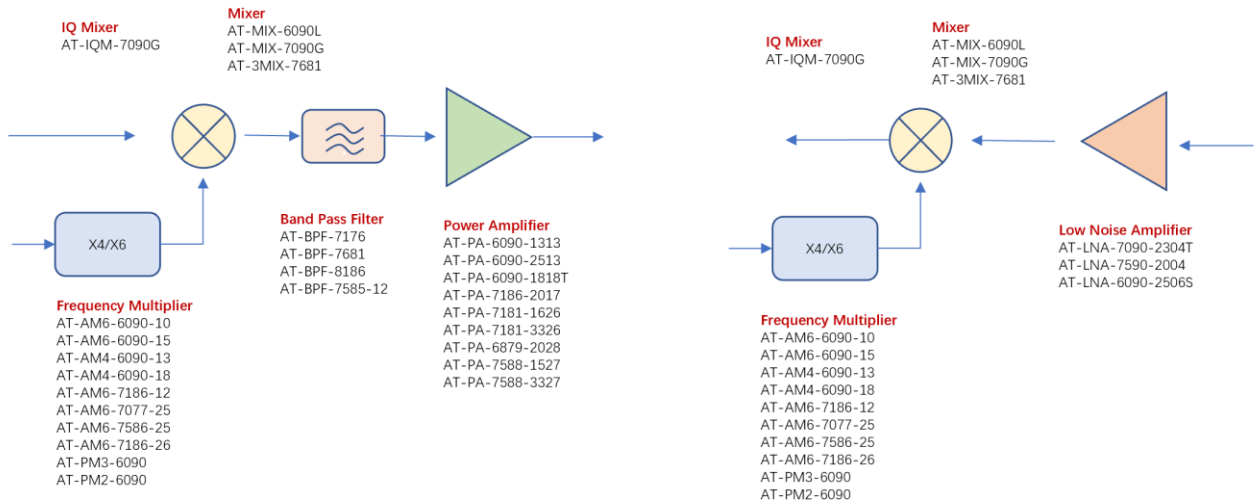

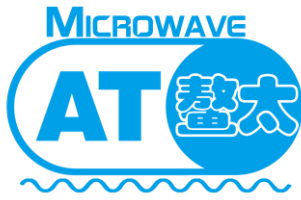

AT-AM6-7186-12

Active Multiplier x6, 71-86GHz Pout=+12dBm

Dimension:

